

Fundamental Group and Covering Space

David Gu

Yau Mathematics Science Center
Tsinghua University

gu@cs.stonybrook.edu

July 5, 2020

Algebraic Topology: Fundamental Group

Orientability-Möbius Band

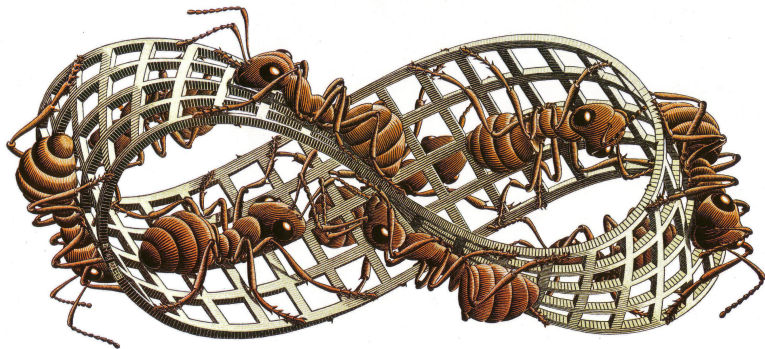
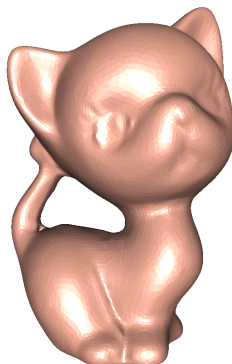

Figure: Escher. Ants

Surface Genus



Topological Sphere



Topological Torus

Figure: How to differentiate the above two surfaces.

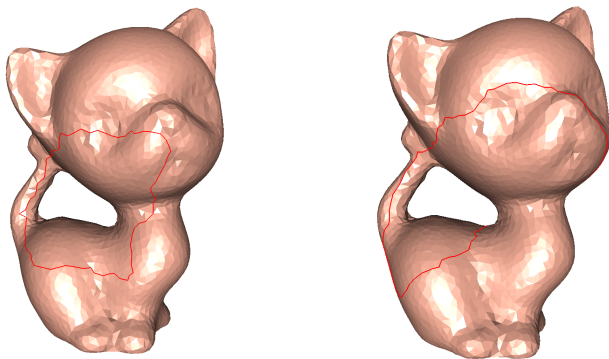

Figure: Check whether all loops on the surface can shrink to a point.

All oriented compact surfaces can be classified by their genus g and number of boundaries b . Therefore, we use (g, b) to represent the topological type of an oriented surface S .

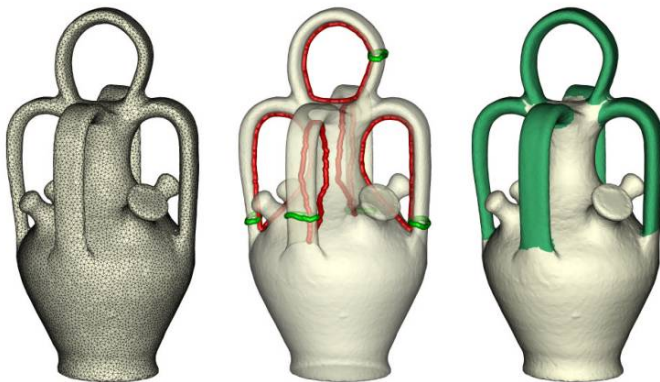

Figure: Handle detection by finding the handle loops and the tunnel loops.

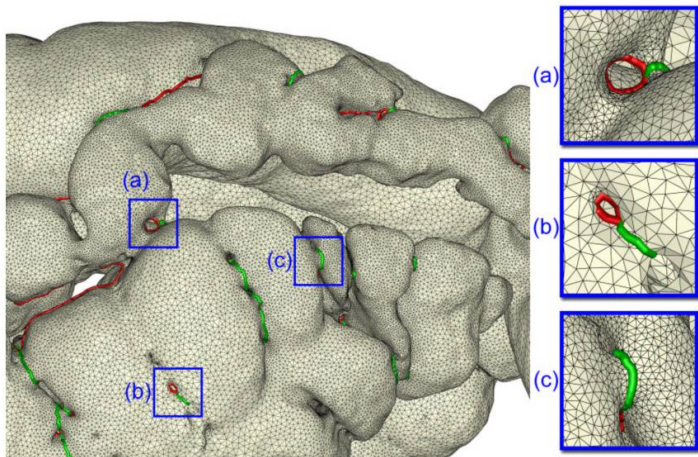

Figure: Topological Denoise in medical imaging.

Philosophy

Associate groups with manifolds, study the topology by analyzing the group structures.

$$\mathcal{C}_1 = \{ \textit{Topological Spaces}, \textit{Homeomorphisms} \}$$

$$\mathcal{C}_2 = \{ \textit{Groups}, \textit{Homomorphisms} \}$$

$$\mathcal{C}_1 \rightarrow \mathcal{C}_2$$

Functor between categories.

Fundamental group

Suppose q is a base point, all the oriented closed curves (loops) through q can be classified by homotopy. All the homotopy classes form the so-called *fundamental group* of S , or *the first homotopy group*, denoted as $\pi_1(S, q)$. The group structure of $\pi_1(S, q)$ determines the topology of S .

Homotopy

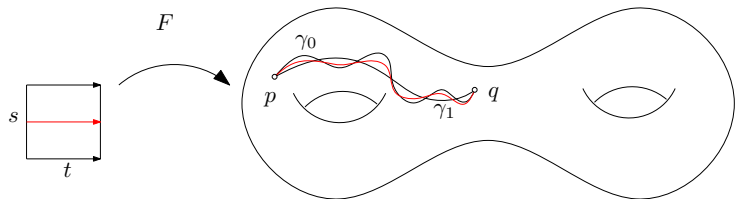

Figure: Path homotopy.

Homotopy

Let S be a two manifold with a base point $p \in S$,

Definition (Curve)

A curve is a continuous mapping $\gamma : [0, 1] \rightarrow S$.

Definition (Loop)

A closed curve through p is a curve, such that $\gamma(0) = \gamma(1) = p$.

Definition (Homotopy)

Let $\gamma_1, \gamma_2 : [0, 1] \rightarrow S$ be two curves. A homotopy connecting γ_1 and γ_2 is a continuous mapping $F : [0, 1] \times [0, 1] \rightarrow S$, such that

$$f(0, t) = \gamma_1(t), f(1, t) = \gamma_2(t).$$

We say γ_1 is homotopic to γ_2 if there exists a homotopy between them.

Homotopy

Lemma

Homotopy relation is an equivalence relation.

Proof.

$\gamma \sim \gamma, F(s, t) = \gamma(t)$. If $\gamma_1 \sim \gamma_2$, $F(s, t)$ is the homotopy, then $F(1 - s, t)$ is the homotopy from γ_2 to γ_1 . □

Corollary

All the loops through the base point can be classified by homotopy relation. The homotopy class of a loops γ is denoted as $[\gamma]$.

Definition (Loop product)

Suppose γ_1, γ_2 are two loops through the base point p , the product of the two loops is defined as

$$\gamma_1 \cdot \gamma_2(t) = \begin{cases} \gamma_1(2t) & 0 \leq t \leq \frac{1}{2} \\ \gamma_2(2t - 1) & \frac{1}{2} \leq t \leq 1 \end{cases}$$

Definition (Loop inverse)

$$\gamma^{-1}(t) = \gamma(1 - t).$$

Loop Inversion

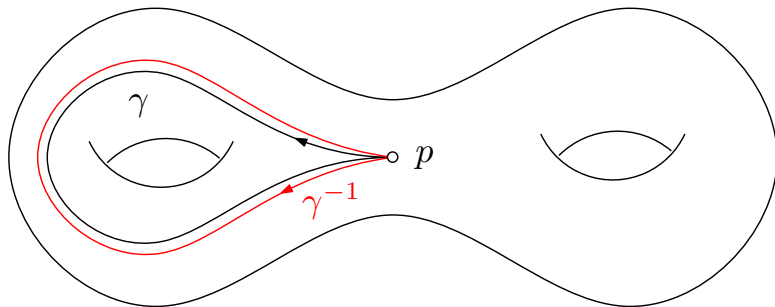

Figure: Loop inversion

Loop Product

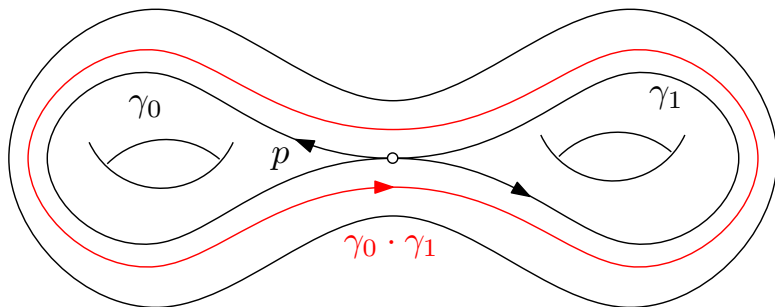

Figure: Loop product

Fundamental Group

Definition (Fundamental Group)

Given a topological space S , fix a base point $p \in S$, the set of all the loops through p is Γ , the set of all the homotopy classes is Γ / \sim . The product is defined as:

$$[\gamma_1] \cdot [\gamma_2] := [\gamma_1 \cdot \gamma_2],$$

the unit element is defined as $[e]$, the inverse element is defined as

$$[\gamma]^{-1} := [\gamma^{-1}],$$

then Γ / \sim forms a group, the fundamental group of S , and is denoted as $\pi_1(S, p)$.

Fundamental Group Representation

Let $G = \{g_1, g_2, \dots, g_n\}$ be n symbols, a word generated by G is a sequence

$$w = g_{i_1}^{e_1} g_{i_2}^{e_2} \cdots g_{i_k}^{e_k}, g_{i_j} \in G, e_j \in \mathbb{Z}.$$

- The empty word \emptyset is also treated as the unit element.
- Given two words $w_1 = \alpha_1 \cdots \alpha_{n_1}$ and $w_2 = \beta_1 \cdots \beta_{n_2}$, the product is defined as concatenation:

$$w_1 \cdot w_2 = \alpha_1 \cdots \alpha_{n_1} \beta_1 \cdots \beta_{n_2}.$$

- The inverse of a word is defined as

$$(g_{i_1}^{e_1} g_{i_2}^{e_2} \cdots g_{i_k}^{e_k})^{-1} = g_{i_k}^{-e_k} g_{i_{k-1}}^{-e_{k-1}} \cdots g_{i_1}^{-e_1}.$$

All words form a group, freely generated by G ,

$$\langle g_1, g_2, \dots, g_n \rangle.$$

The relations $R = \{R_1, R_2, \dots, R_m\}$ are m words, such that we can replace R_k by the empty word.

Definition (word equivalence relation)

Two words are equivalent if we can transform one to the other by finite many steps of the following two elementary transformations:

- 1 Insert a relation word anywhere.

$$\alpha_1 \cdots \alpha_i \alpha_{i+1} \cdots \alpha_l \mapsto \alpha_1 \cdots \alpha_i R_k \alpha_{i+1} \cdots \alpha_l$$

- 2 If a subword is a relation word, remove it from the word.

$$\alpha_1 \cdots \alpha_i R_k \alpha_{i+1} \cdots \alpha_l \mapsto \alpha_1 \cdots \alpha_i \alpha_{i+1} \cdots \alpha_l$$

Definition (Word Group)

Given a set of generators G and a set of relations R , all the equivalence classes of the words generated by G form a group under the concatenation, denoted as

$$\langle g_1, g_2, \dots, g_n \mid R_1, R_2, \dots, R_m \rangle.$$

If there is no relations, then the word group is called a free group.

Intersection Index

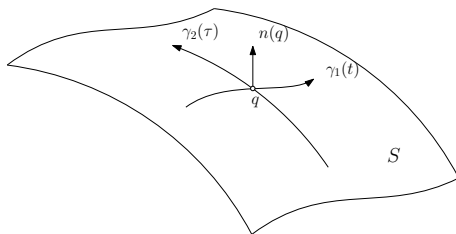

Definition (Intersection Index)

Suppose $\gamma_1(t), \gamma_2(\tau) \subset S$ intersect at $q \in S$, the tangent vectors satisfy

$$\frac{d\gamma_1(t)}{dt} \times \frac{d\gamma_2(\tau)}{d\tau} \cdot \mathbf{n}(q) > 0,$$

then the index of the intersection point q of γ_1 and γ_2 is $+1$, denoted as $\text{Ind}(\gamma_1, \gamma_2, q) = +1$. If the mixed product is zero or negative, then the index is 0 or -1 .

Algebraic Intersection Number

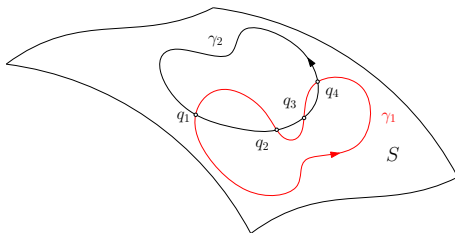

Figure: Algebraic intersection number

Definition (Algebraic Intersection Number)

The algebraic intersection number of $\gamma_1(t), \gamma_2(\tau) \subset S$ is defined as

$$\gamma_1 \cdot \gamma_2 := \sum_{q_i \in \gamma_1 \cap \gamma_2} \text{Ind}(\gamma_1, \gamma_2, q_i).$$

Algebraic Intersection Number

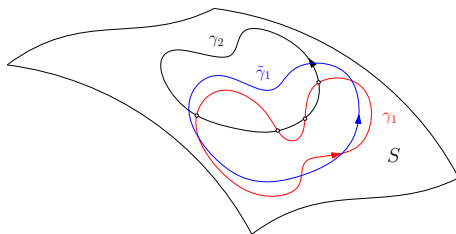

Figure: Algebraic intersection number

Algebraic Intersection Number Homotopy Invariance

Suppose γ_1 is homotopic to $\tilde{\gamma}_1$, then the algebraic intersection number

$$\gamma_1 \cdot \gamma_2 = \tilde{\gamma}_1 \cdot \gamma_2.$$

Canonical Representation of $\pi_1(S, p)$

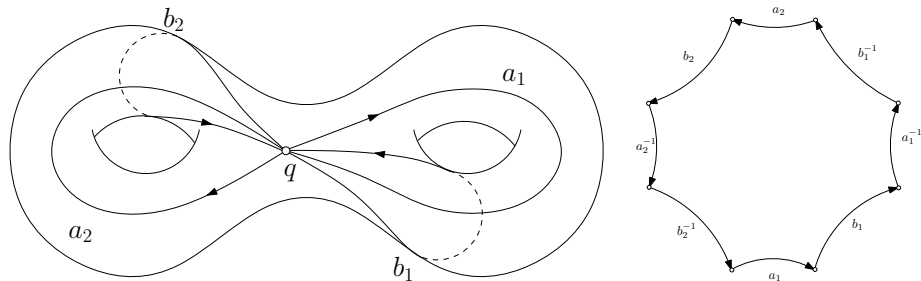

Figure: Canonical fundamental group representation.

Canonical Representation of $\pi_1(S, p)$

Definition (Canonical Basis)

Suppose S is a compact, oriented surface, there exists a set of generators of the fundamental group $\pi_1(S, p)$,

$$G = \{[a_1], [b_1], [a_2], [b_2], \dots, [a_g], [b_g]\}$$

such that

$$a_i \cdot b_j = \delta_{ij}, a_i \cdot a_j = 0, b_i \cdot b_j = 0,$$

where $a_i \cdot b_j$ represents the algebraic intersection number of loops a_i and b_j , δ_{ij} is the Kronecker symbol, then G is called a set of canonical basis of $\pi_1(S, p)$.

Canonical Representation of $\pi_1(S, p)$

Theorem (Surface Fundamental Group Canonical Representation)

Suppose S is a compact, oriented surface, $p \in S$ is a fixed point, the fundamental group has a canonical representation,

$$\pi_1(S, p) = \langle a_1, b_1, a_2, b_2, \dots, a_g, b_g \mid \prod_{i=1}^g [a_i, b_i] \rangle,$$

where

$$[a_i, b_i] = a_i b_i a_i^{-1} b_i^{-1},$$

g is the genus of the surface.

Canonical Representation of $\pi_1(S, p)$

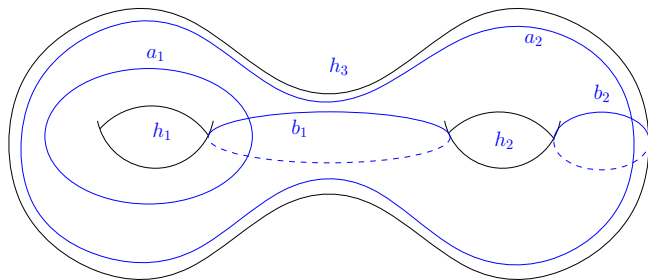

Figure: Canonical representation of $\pi_1(S)$.

Non-uniqueness

The canonical representation of the fundamental group of the surface is not unique. It is NP hard to verify if two given representations are isomorphic.

Theorem

Suppose $\pi_1(S_1, p_1)$ is isomorphic to $\pi_2(S_2, p_2)$, then S_1 is homeomorphic to S_2 , and vice versa.

Proof.

For each surface, find a canonical basis, slice the surface along the basis to get a $4g$ polygonal scheme, then construct a homeomorphism between the polygonal schema with consistent boundary condition. \square

Seifert-Van Kampen Theorem

Theorem (Seifert-Van Kampen)

Topological space M is decomposed into the union of U and V , the intersection of U and V is W , $M = U \cup V$, $W = U \cap V$, where U, V and W are path connected. $i : W \rightarrow U, j : W \rightarrow V$ are the inclusions. Pick a base point $p \in W$, the fundamental groups

$$\pi_1(U, p) = \langle u_1, \dots, u_k \mid \alpha_1, \dots, \alpha_l \rangle$$

$$\pi_1(V, p) = \langle v_1, \dots, v_m \mid \beta_1, \dots, \beta_n \rangle$$

$$\pi_1(W, p) = \langle w_1, \dots, w_p \mid \gamma_1, \dots, \gamma_q \rangle$$

then the $\pi_1(M, p)$ is given by

$$\pi_1(M, p) = \langle u_1, \dots, u_k, v_1, \dots, v_m \mid \alpha_i, \beta_j, i(w_1)j(w_1)^{-1}, \dots, i(w_p)j(w_p)^{-1} \rangle$$

Canonical Representation of $\pi_1(S, p)$

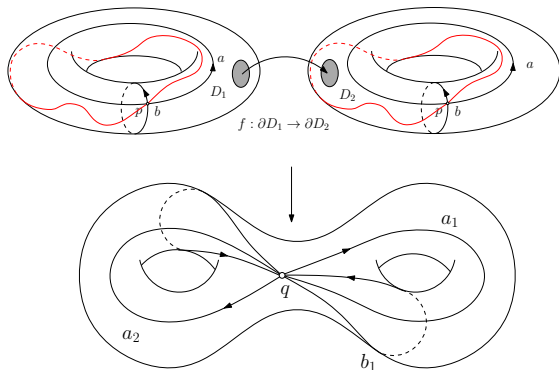

Definition (Connected Sum)

Let S_1 and S_2 be two surfaces, $D_1 \subset S_1$ and $D_2 \subset S_2$ are two topological disks. $f : \partial D_1 \rightarrow \partial D_2$ is a homeomorphism between the boundaries of the disks. The connected sum is $S_1 \oplus S_2 := S_1 \cup S_2 / \{p \sim f(p)\}$.

Theorem (Surface Topological Classification)

All the compact closed surfaces can be represented as

$$S \cong T^2 \oplus T^2 \oplus \dots \oplus T^2$$

for oriented surfaces, or

$$S \cong RP^2 \oplus RP^2 \oplus \dots \oplus RP^2.$$

RP^2 is gluing a Möbius band with a disk along its single boundary.

Canonical Representation of $\pi_1(S, p)$

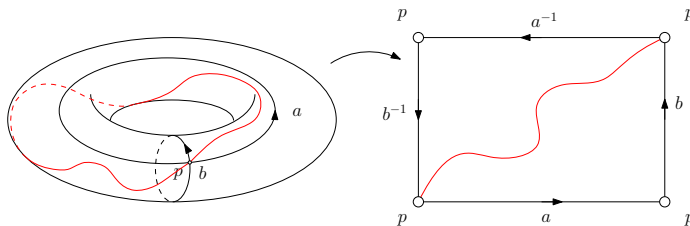

Figure: $\pi_1(T, p) = \langle a, b | aba^{-1}b^{-1} \rangle$.

Lemma

The fundamental group of a torus is $\pi_1(T, p) = \langle a, b | aba^{-1}b^{-1} \rangle$.

Proof.

Homotopic deform a loop γ , such that γ intersects a and b only at p ; decompose γ to $\gamma_1\gamma_2 \dots \gamma_k$, such that γ_i starts and ends at p , the interior doesn't intersect a and b ; each γ_i is generated by a, b . □

Canonical Representation of $\pi_1(S, p)$

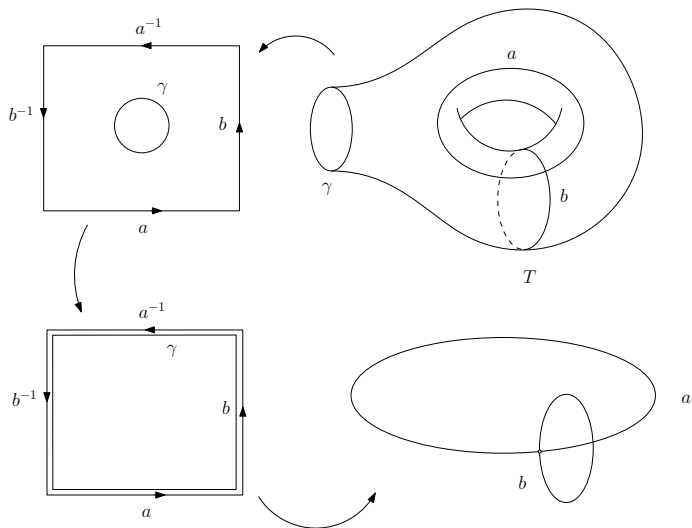

Figure: Punctured torus, fundamental group $\pi_1(T \setminus \{q\}, p) = \langle a, b \rangle$.

Canonical Representation of $\pi_1(S, p)$

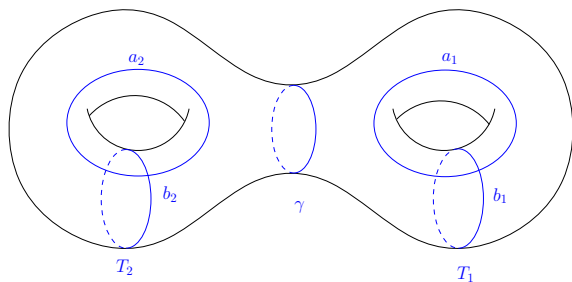

Figure: Divide conquer method.

Fundamental Groups

$$\pi_1(T_1, p) = \langle a_1, b_1 \rangle, \quad \pi_1(T_2, p) = \langle a_2, b_2 \rangle, \quad \pi_1(T_1 \cap T_2, p) = \langle \gamma \rangle$$

Canonical Representation of Fundamental Group

Theorem

Show that $\pi_1(S)$ is $\langle a_1, b_1, \dots, a_g, b_g \mid \prod_{i=1}^g [a_i, b_i] \rangle$ for a surface $S = \bigoplus_{i=1}^g T^2$.

Proof.

By induction. If $g = 1$, obvious. Let $g = 2$,

$$\begin{aligned}\pi_1(T_1) &= \langle a_1, b_1 \rangle \\ \pi_1(T_2) &= \langle a_2, b_2 \rangle \\ \pi_1(T_1 \cap T_2) &= \langle \gamma \rangle\end{aligned}$$

$[\gamma] = a_1 b_1 a_1^{-1} b_1^{-1}$ in $\pi_1(T_1)$, $[\gamma] = (a_2 b_2 a_2^{-1} b_2^{-1})^{-1}$ in $\pi_1(T_2)$, so

$$\pi_1(T_1 \cup T_2) = \langle a_1, b_1, a_2, b_2 \mid [a_1, b_1][a_2, b_2] \rangle.$$

where $[a_k, b_k] = a_k b_k a_k^{-1} b_k^{-1}$.



Canonical Representation of Fundamental Group

continued.

Suppose it is true for $g - 1$ case. Then for g case, the intersection is an annulus,

$$\begin{aligned}\pi_1(T_1 \cup T_2 \dots T_{g-1}) &= \langle a_1, b_1, \dots, a_{g-1}, b_{g-1} | \prod_{k=1}^{g-1} [a_k, b_k] \rangle \\ \pi_1(T_g) &= \langle a_g, b_g | [a_g, b_g] \rangle \\ \pi_1(S \cap T_g) &= \langle \gamma \rangle\end{aligned}$$

$[\gamma] = \pi_{k=1}^{g-1} [a_k, b_k]$ in $\pi_1(T_1 \cup T_2 \dots T_{g-1})$ and $[a_g, b_g] \in \pi_1(T_g)$. □

Computational Topology: Fundamental Group

Cut Graph

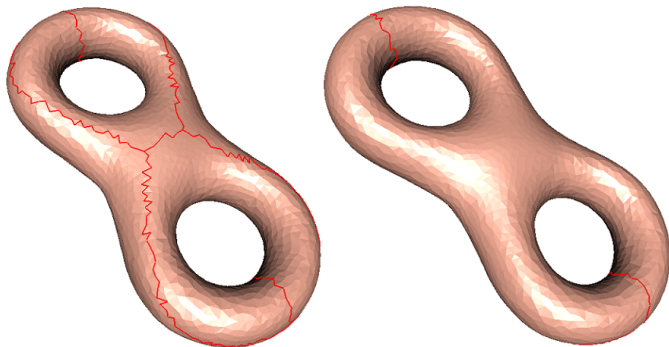

Figure: Cut graph of a genus two surface.

Definition (Cut Graph)

Γ is a graph on the surface S , such that $S \setminus \Gamma$ is a topological disk, then Γ is a cut graph of S .

Cut Graph Algorithm

Input : A closed triangle mesh M ;

Output: A cut graph Γ of M .

- 1 Compute the dual mesh \bar{M} of the input mesh M ;
- 2 Compute a spanning tree \bar{T} of \bar{M} ;
- 3 The cut graph is given by

$$\Gamma := \{e \in M \mid \bar{e} \notin \bar{T}\}.$$

Fundamental Group Generators

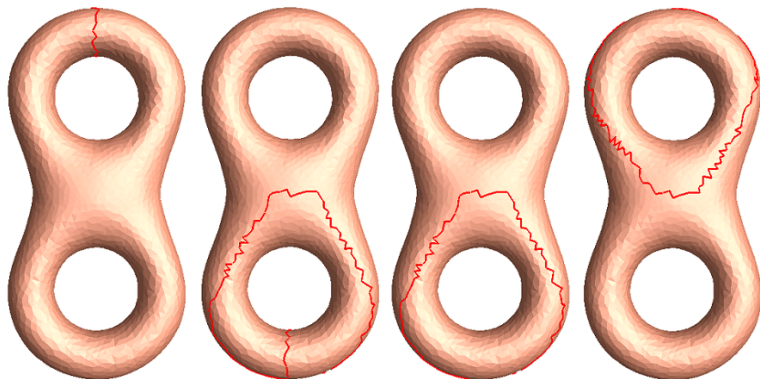

Figure: Fundamental group generators of a genus two surface.

Fundamental Group Generators Algorithm

Input : A closed triangle mesh M ;

Output: A set of generators of $\pi_1(M, p)$.

- 1 Compute a cut graph Γ of the input mesh M ;
- 2 Compute a spanning tree T of Γ ;
- 3 Select an edge $e_i \in \Gamma \setminus T$, $e_i \cup T$ has a unique loop γ_i ;
- 4 $\{\gamma_1, \gamma_2, \dots, \gamma_k\}$ is a set of generators of the fundamental group of M .

Fundamental Group Relations Algorithm

Input : A closed triangle mesh M ;

Output: The relations in $\pi_1(M, p)$.

- 1 Compute a cut graph Γ of the input mesh M ;
- 2 Compute a spanning tree T of Γ , $\Gamma \setminus T = \{e_1, e_2, \dots, e_k\}$;
- 3 For each oriented edge, $e_i \cup T$ has an oriented loop γ_i ,
 $\{\gamma_1, \gamma_2, \dots, \gamma_k\}$;
- 4 Cut the mesh M along Γ to obtain \bar{M} ;
- 5 Set Let $\gamma = \partial\bar{M}$, traverse γ . Set $w = \emptyset$, once $e_i^{\pm 1}$ is encountered, append $\gamma_i^{\pm 1}$ to w , $w \leftarrow w\gamma_i^{\pm 1}$.

Algebraic Topology: Universal Covering Space

Universal Covering Space

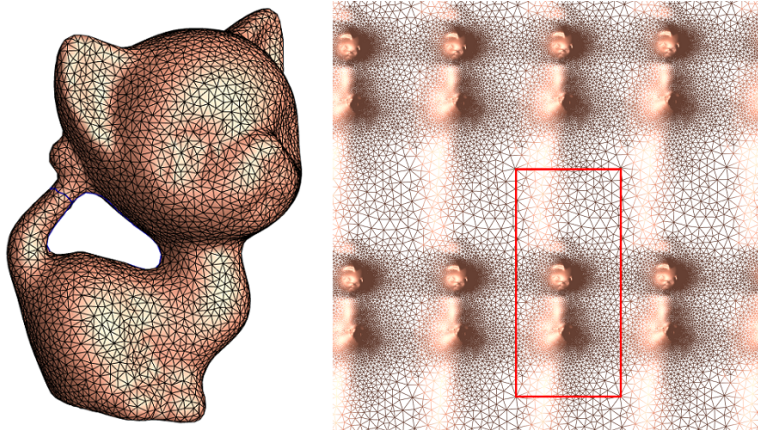

Figure: Universal Covering Space

Definition (Covering Space)

Given topological spaces \tilde{S} and S , a continuous map $p : \tilde{S} \rightarrow S$ is surjective, such that for each point $q \in S$, there is a neighborhood U of q , its preimage $p^{-1}(U) = \cup_i \tilde{U}_i$ is a disjoint union of open sets \tilde{U}_i , and the restriction of p on each \tilde{U}_i is a local homeomorphism, then (\tilde{S}, p) is a *covering space* of S , p is called a *projection map*.

Definition (Deck Transformation)

The automorphisms of \tilde{S} , $\tau : \tilde{S} \rightarrow \tilde{S}$, are called *deck transformations*, if they satisfy $p \circ \tau = p$. All the deck transformations form a group, the *covering group*, and denoted as $Deck(\tilde{S})$.

Suppose $\tilde{q} \in \tilde{S}$, $p(\tilde{q}) = q$. The projection map $p : \tilde{S} \rightarrow S$ induces a homomorphism between their fundamental groups, $p_* : \pi_1(\tilde{S}, \tilde{q}) \rightarrow \pi_1(S, q)$, if $p_*\pi_1(\tilde{S}, \tilde{q})$ is a normal subgroup of $\pi_1(S, q)$ then

Theorem (Covering Group Structure)

The quotient group of $\frac{\pi_1(S)}{p_*\pi_1(\tilde{S}, \tilde{q})}$ is isomorphic to the deck transformation group of \tilde{S} .

$$\frac{\pi_1(S, q)}{p_*\pi_1(\tilde{S}, \tilde{q})} \cong \text{Deck}(\tilde{S}).$$

Definition (Universal Covering Space)

If a covering space \tilde{S} is simply connected (i.e. $\pi_1(\tilde{S}) = \{e\}$), then \tilde{S} is called a *universal covering space* of S .

For universal covering space

$$\pi_1(\pi) \cong \text{Deck}(\tilde{S}).$$

Namely, the fundamental group of the base space is isomorphic to the deck transformation group of the universal covering space.

Universal Covering Space

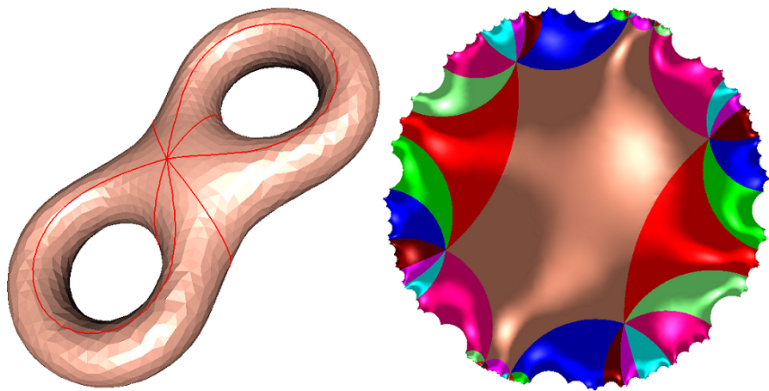

Figure: Universal Covering Space of a genus two surface.

Universal Covering Space

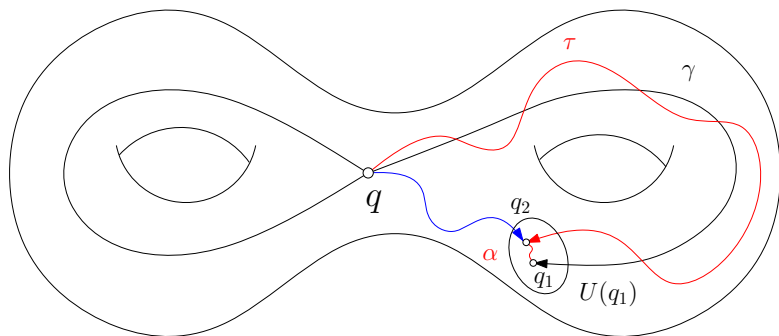

Figure: Universal Covering Space Construction.

Path homotopy classes form the universal covering space.

Universal Covering Space

Theorem

Suppose the topological manifold is path connected, then there is a universal covering space $p : \tilde{S} \rightarrow S$.

Proof.

Fix a base point $q \in S$, consider all the paths starting from q , $\Gamma := \{\gamma : [0, 1] \rightarrow S \mid \gamma(0) = q\}$. Define $\tilde{S} := \Gamma / \sim$, the homotopy classes of paths in Γ . Pick a path $\gamma \in \Gamma$, $\gamma(1) = q_0$, let $U \subset S$ be an open set of q_1 . For each point $q' \in U$, there is a path $\alpha(q') \subset U$ connecting q' to q_0 . Then we define an open set $\tilde{U} \subset \tilde{S}$ of $[\gamma]$ as

$$\tilde{U} := \{[\tau] \mid \tau(1) \in U, \tau \cdot \alpha(\tau(1)) \sim \gamma\}.$$

The $\{\tilde{U}\}$ define a topology of \tilde{S} . $p : \tilde{S} \rightarrow S$, $[\gamma] \mapsto \gamma(1)$ is a universal covering space of S . □

Lifting to Universal Covering Space

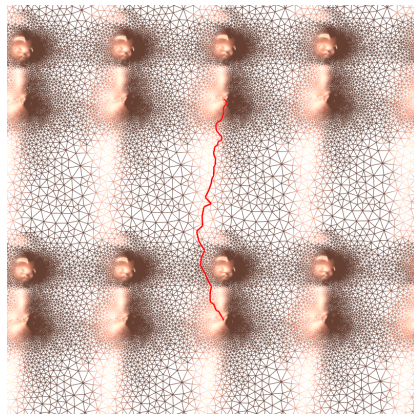
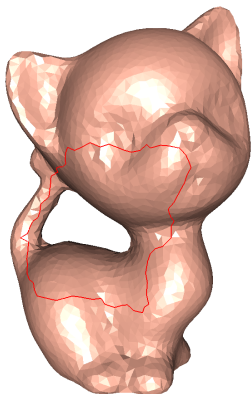

Figure: Universal Covering Space

Lifting to Universal Covering Space

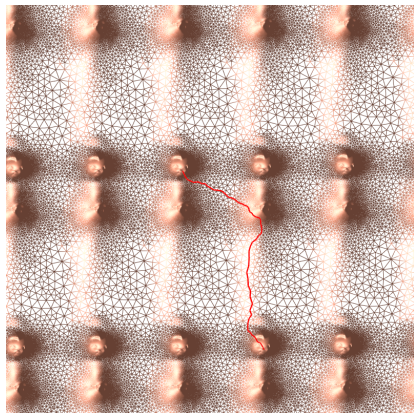
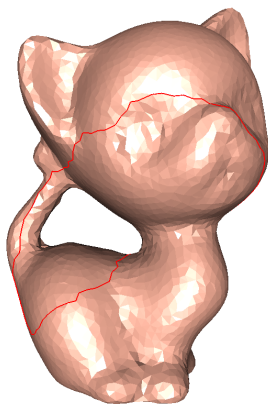

Figure: Universal Covering Space

Lifting to Universal Covering Space

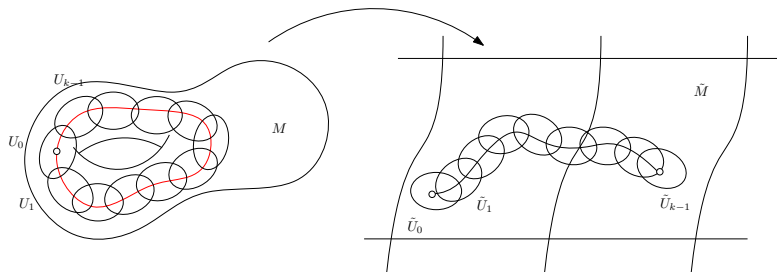

Figure: Lifting to the Universal Covering Space

Lifting to Universal Covering Space

Let (\tilde{S}, p) be the universal covering space of S , q be the base point. The orbit of base is $p^{-1}(q) = \{\tilde{q}_k\}$. Given a loop through q , there exists a unique lift of γ , $\tilde{\gamma} \subset \tilde{S}$, starting from \tilde{q}_0 .

Lemma

γ_1 and γ_2 are two loops through the base point, their lifts are $\tilde{\gamma}_1$ and $\tilde{\gamma}_2$. $\gamma_1 \sim \gamma_2$ if and only if the end points of $\tilde{\gamma}_1$ and $\tilde{\gamma}_2$ coincide.

$$\begin{array}{ccc} [0, 1] & \xrightarrow{\tilde{\gamma}} & \tilde{M} \\ \downarrow id & & \downarrow p \\ [0, 1] & \xrightarrow{\gamma} & M \end{array}$$

Graph fundamental group

Let G be an unoriented graph, T is a spanning tree of G ,
 $G - T = \{e_1, e_2, \dots, e_n\}$, where e_k is an edge not in the tree. Then
 $T \cup e_k$ has a unique loop γ_k . Choose one orientation of γ_k .

Lemma

The fundamental group of G is $\pi_1(G) = \langle \gamma_1, \gamma_2, \dots, \gamma_n \rangle$, which is a free group.

Definition (CW-cell decomposition)

A k dimensional cell D_k is a k dimensional topological disk. Suppose M is a n -dimensional manifold.

- 1 0-skeleton S_0 is the union of a set of 0-cells.
- 2 k -skeleton S_k

$$S_k = S_{k-1} \cup D_k^1 \cup D_k^2 \cdots \cup D_k^{n_k},$$

such that

$$\partial D_k^i \subset S_{k-1}.$$

The k -skeleton is constructed by gluing k -cells to the $k - 1$ skeleton, all the boundaries of the cells are in the $k - 1$ skeleton.

- 3 $S_n = M$.

Theorem (CW-cell decomposition)

$$\pi_1(S_2) = \pi_1(S_3) \cdots \pi_1(S_n) = \pi_1(M)$$

Proof.

using induction. $S_2 \cap D_3^1$ is ∂D_3^1 , which is a topological sphere.
 $\pi_1(D_3^1) = \langle e \rangle$, $\pi_1(\mathbb{S}^2)$ is $\langle e \rangle$. □

Computational Topology: Universal Covering Space

Algorithm for Universal Covering Space

Universal Covering Space Algorithm

Input : A closed triangle mesh M ;

Output: A finite portion of the universal covering space \tilde{M} .

- 1 Compute a cut graph Γ of M , divide Γ into nodes and oriented segments, $\{s_1, s_2, \dots, s_k\}$;
- 2 Slice M along Γ to obtain one fundamental domain \bar{M} ;
- 3 Initialize $\tilde{M} \leftarrow \bar{M}$
- 4 Choose an oriented segment s_i on the boundary of \tilde{M} , glue a copy of \bar{M} with \tilde{M} along s_i ,

$$\tilde{M} \leftarrow \tilde{M} \cup_{\partial\tilde{M} \supset s_i \sim s_i^{-1} \subset \partial\bar{M}} \bar{M}$$

- 5 Trace the boundary of \tilde{M} , if there are two adjacent segments $s_i, s_{i+1} \subset \partial\tilde{M}$, such that $s_i^{-1} = s_{i+1}$, then glue them together;
- 6 Repeat step 4 and step 5, until \tilde{M} is large enough.

Algorithm for Homotopy Detection

Homotopy Detection Algorithm

Input : A closed triangle mesh M , two loops γ_1 and γ_2 through a base point p ;

Output: Verify whether $\gamma_1 \sim \gamma_2$.

- 1 Compute a finite portion of the universal covering space \tilde{M} of M ;
- 2 Lift $\gamma_1 \cdot \gamma_2^{-1}$ to \tilde{M} , the lifted path is $\tilde{\gamma}$;
- 3 If $\tilde{\gamma}$ is a closed loop, then return Yes; otherwise, return No.