

Modular Neural Networks

Group 9

Arjun Bora

Bhavana Raj Kanthur Murnad

Priyam Sirohi

Course: CSE 537

Instructor: Professor Anita Wasilewska

References

- <http://www.sciencedirect.com/science/article/pii/S0925231213001604>
- http://www.kovan.ceng.metu.edu.tr/~emre/literature/LOMNN/Modular_Neural_Networks_A_Survey.pdf
- <http://citeseerx.ist.psu.edu/viewdoc/download?doi=10.1.1.7.6594&rep=rep1&type=pdf>
- <http://www.teco.edu/~albrecht/neuro/report.pdf>
- https://en.wikipedia.org/wiki/Modular_neural_network
- A Parallel and Modular Multi-Sieving Neural Network Architecture for Constructive Learning, by Lu et al.
- A modular neural network architecture with concept, by Yi Dinga, Qi Fenga, Tianjiang Wanga, Xian Fub
- <https://www3.cs.stonybrook.edu/~cse634/>

Overview

- History of Neural networks
- Motivation behind Neural networks
- Biological neural networks
- Modular neural networks
- Motivation behind neural networks
- A paper study on a parallel and fault tolerant MNN
- Benefits

History of Neural Networks

- In 1943, neurophysiologist Warren McCulloch and mathematician Walter Pitts modelled a simple neural network using electrical circuits.
- Nathaniel Rochester from the IBM research laboratories simulated a hypothetical network and failed in his first attempt.
- In 1959, Bernard Widrow and Marcian Hoff of Stanford developed models called "ADALINE" and "MADALINE."
- ADALINE was developed to recognize binary patterns so that if it was reading streaming bits from a phone line, it could predict the next bit. MADALINE was the first neural network applied to a real world problem, using an adaptive filter that eliminates echoes on phone lines. While the system is as ancient as air traffic control systems, like air traffic control systems, it is **still in commercial use !!**

What is a Neural Network ?

- ▶ An **Artificial Neural Network (ANN)** is an information processing paradigm that is inspired by the way biological nervous systems work.
- ▶ It is composed of a large number of highly interconnected processing elements (neurons) .
- ▶ An ANN is configured for a specific application, such as **pattern recognition** or **data classification**, through a learning process.
- ▶ Involves adjustments to the synaptic connections that exist between the neurons.

Motivation behind Neural Networks

- Historically, the Biological Neural Network (BNN) structure was the main motivation behind building artificial NNs.
- NN founders aimed at mimicing the functionality of the human brain in order to build useful computational models.
- NNs are considered, by many biologists, as one of the important methods which will help us understand the biological neural system itself.

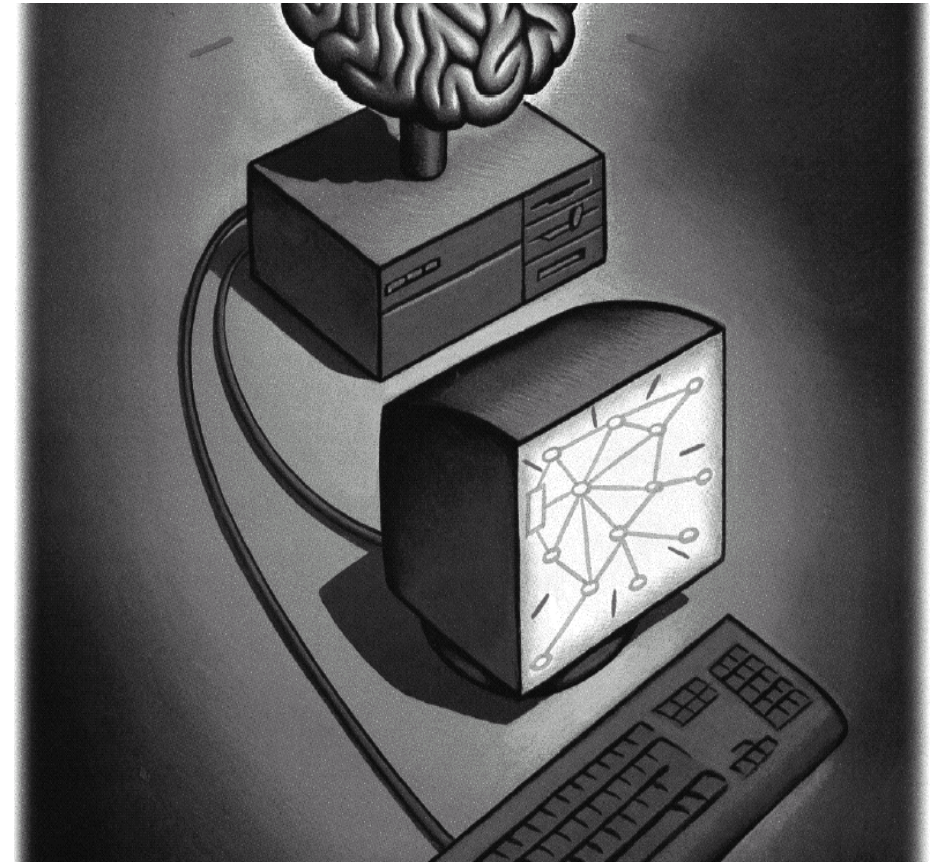

Biological Neural Network

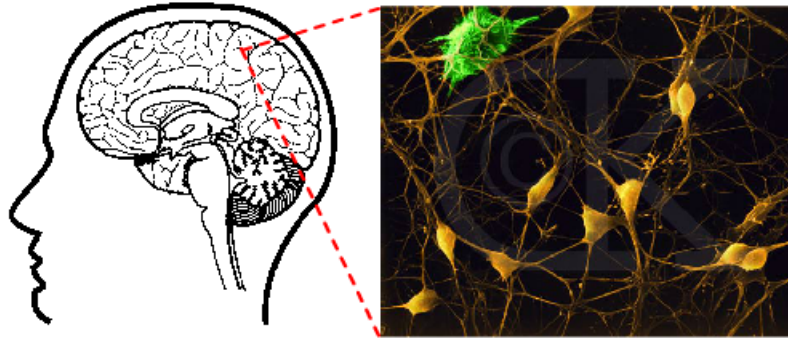

- Each of the yellow blobs in the picture above are neuronal cell bodies **Soma**.
- The lines are the input and output channels (**dendrites and axons**) which connect them.
- Each neuron receives **electrochemical inputs** from other neurons at the dendrites.

Biological Neural Network

- If the sum of these electrical inputs is sufficiently powerful to activate the neuron, it **fires** or transmits these signals to other neurons.
- It is important to note that a **neuron fires only if the total signal received at the cell body exceeds a certain level.**
- Each neuron performs a weighted sum of its inputs, and fires a binary signal if the total input exceeds a certain level.
- **This is the model on which artificial neural networks are based.**

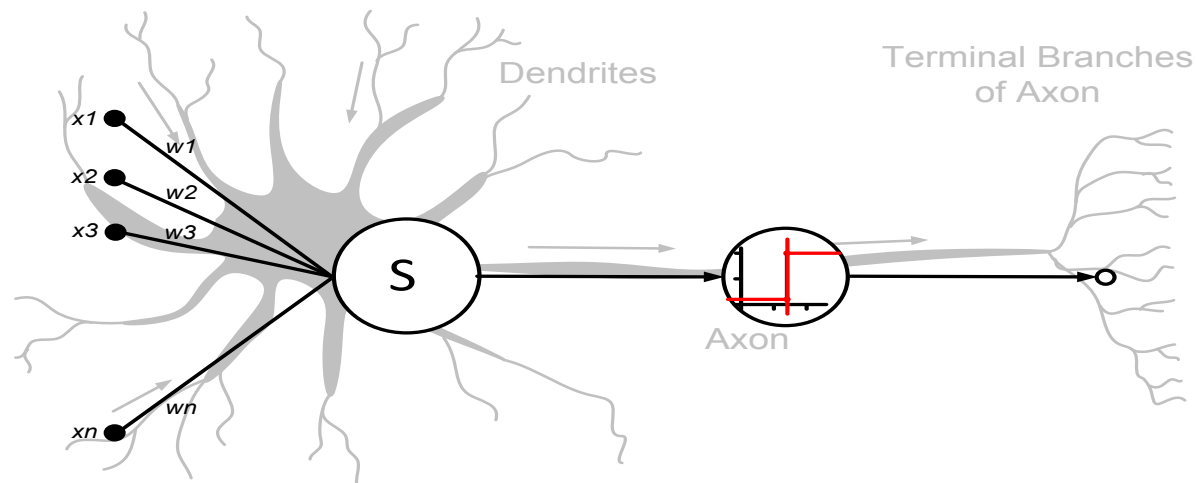

Modularity

- Biological modularity is the first idea which motivated many MNN designs.
- Brain is modular on different spatial scales.
- On the smallest scale, synapses are clustered on dendrites.
- On the largest scale, the brain is composed of several anatomically and functionally distinct areas.

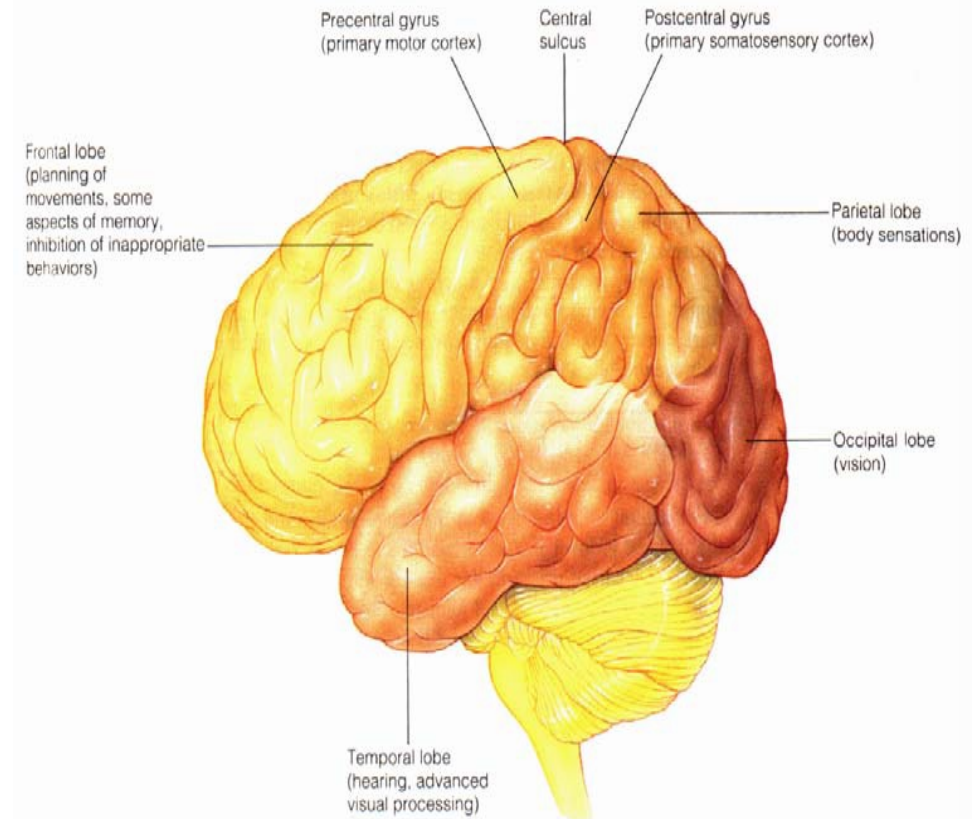

Modularity in Neural networks

- The most used artificial neural networks have a monolithic structure.
- A lot of the models work on fully connected networks or layers.
- These networks perform well on a very small input space.
- The complexity increases and the performance decreases rapidly with a growing input dimension.
- Different models of neural networks combined into a single system form **modular neural networks** .
- Each single network is made into a module that can be freely intermixed with modules of other types in that system.

Multiple Neural Networks

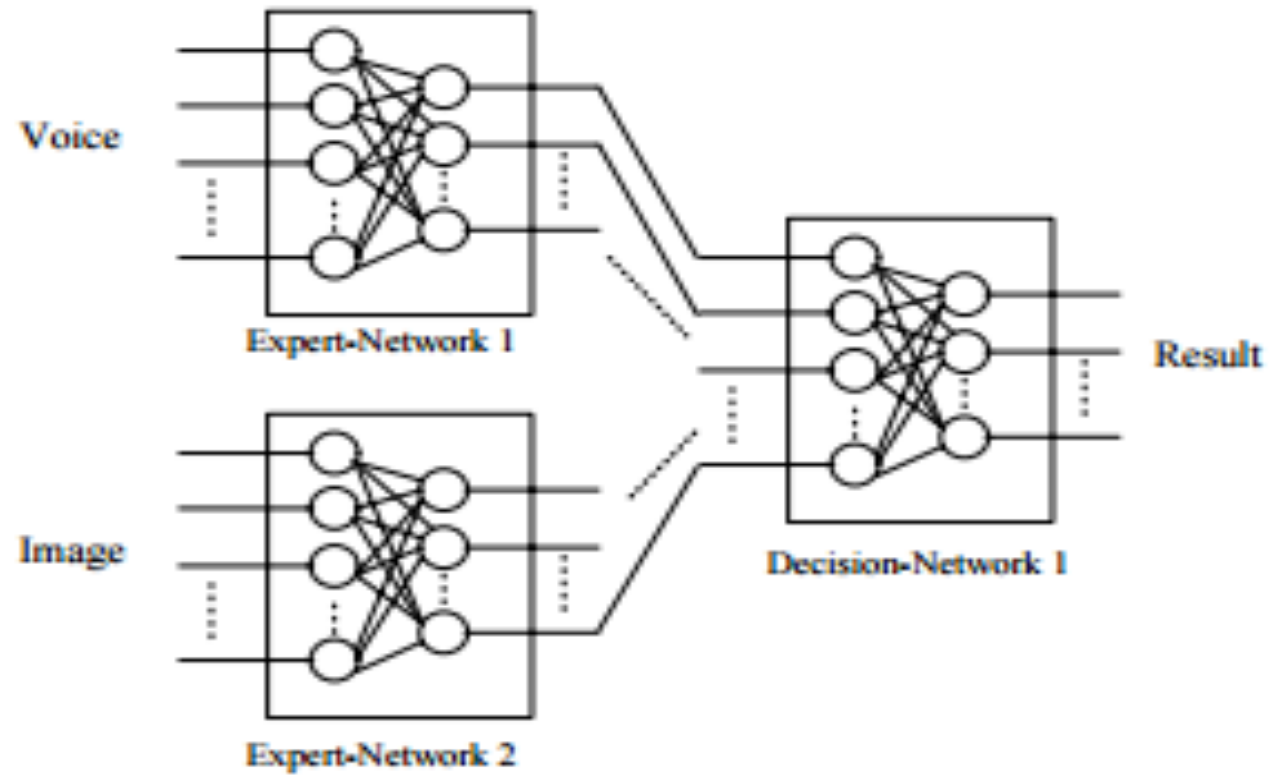

Multiple neural networks

- Multiple Neural Networks are used for strongly separated architectures.
- Each of the networks works independently on its own domain.
- The single networks are built and trained for their specific task. The final decision is made on the results of the individual networks .
- The decision system can be implemented by a logical majority vote function, another neural network or a rule based expert system may be employed.
- The individual network is trained on its domain only. The output by a single network is according to its specific input.
- In the example given in the figure , one of the networks is trained to **identify a person by voice** while the other network is trained to identify the **person by vision**.

Modular Neural Networks

With Modularity

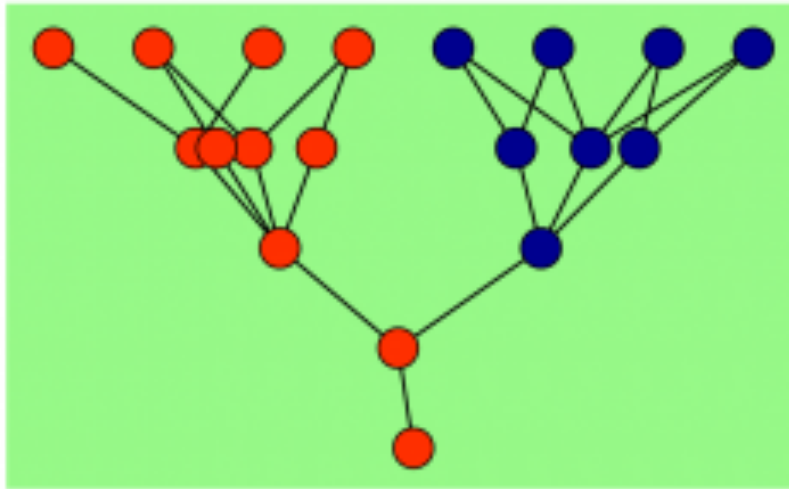

Without Modularity

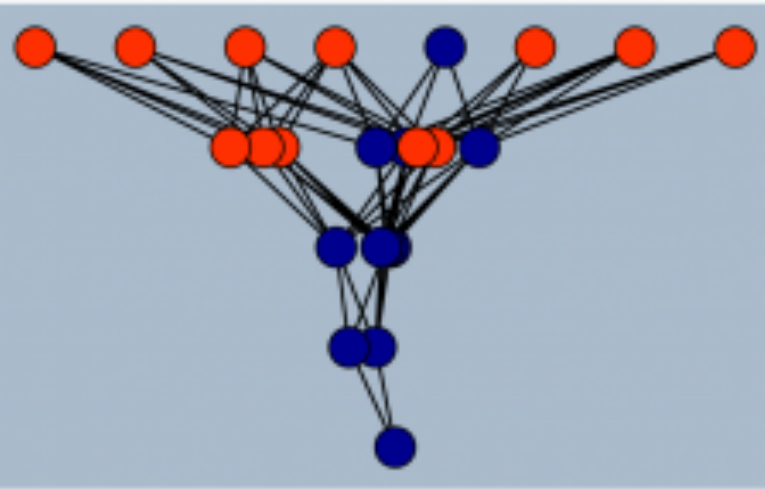

Modular NNetworks

- Modular neural network architecture builds a bigger network by using modules as building blocks.
- The architecture of a single module is simpler and the subnetworks are smaller than a monolithic network.
- Due to the structural modifications the task the module has to learn is in general easier than the whole task of the network.
- The modules are independent to a certain level which allows the system to work in parallel.
- For this modular approach it is always necessary to have a control system to enable the modules to work together in a useful way

Modular Multi-Sieving Neural Network Architecture

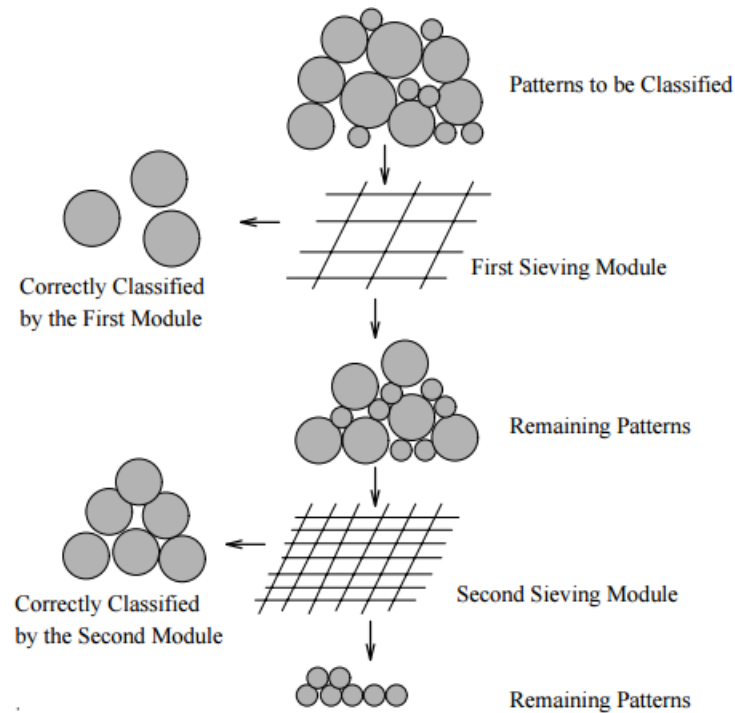

Modular Multi-Sieving Neural Network Architecture

- The patterns are classified by this algorithm on different levels.
- In the first level , a very rough sieve, some patterns may be recognized correctly while others will not. The correctly classified samples are taken out of the training set.
- The next level , a less rough sieve, is only trained on the remaining ones. After the training of this level the correctly recognized patterns are removed from the training set.
- The remaining patterns form the training set for the next level.
- This process is repeated until all patterns are classified correctly.
- Each level of learning , **each sieve generates a neural network** with the ability to recognize a subset of the original training set. These networks called sieving modules face a simpler recognition task than the whole problem.

Motivations for Modular Neural Network

- **Biological motivations :**
 - **Modularity, Functional specialization concept, Fault tolerance, scalability**
- **Psychological motivations**
 - **Learning in stages,**
 - **Decomposing tasks**
 - A way to cope NP-completeness, some papers used MNN to solve travelling salesman problem
- **Hardware motivations**
 - Hardware reaching theoretical limits, need for speed and less memory structures
- **Computational motivations**
 - improves the speed of learning by reducing the effect of conflicting training information (or crosstalk). Crosstalk degrades the ability of the network to perform correctly for a group of patterns.

MNN Design stages

- **Efficiency**
 - multimodule decision-making strategy has to take part in order to integrate the different local decisions (at the modular level) into a global one.
- **reasonable balance** between sub-tasks simplification and decision-making efficiency
 - sub-tasks as simple as possible
 - give the multimodule decision-making strategy enough information

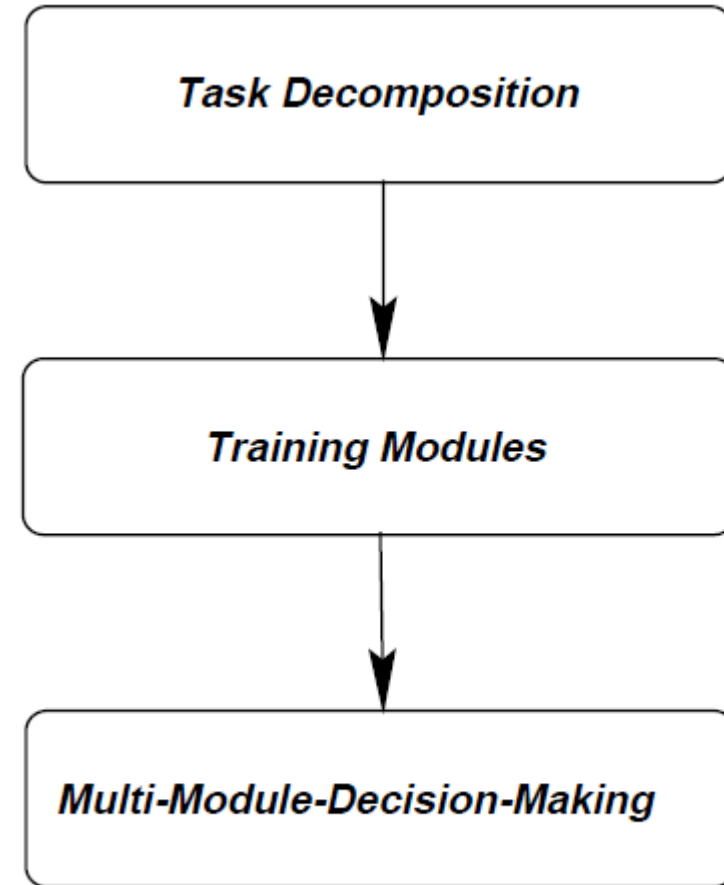

The general three main stages for designing MNN.

MNN Architectures

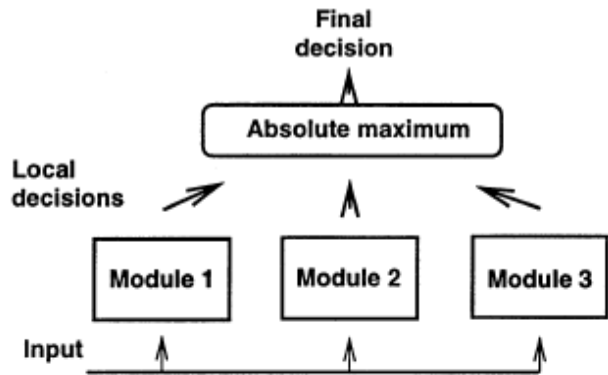

Decoupled modules

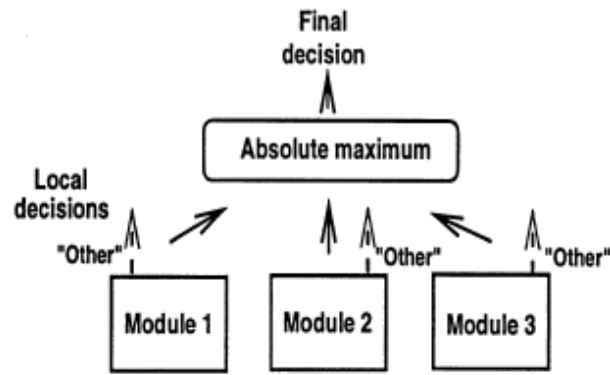

Other-o/p model

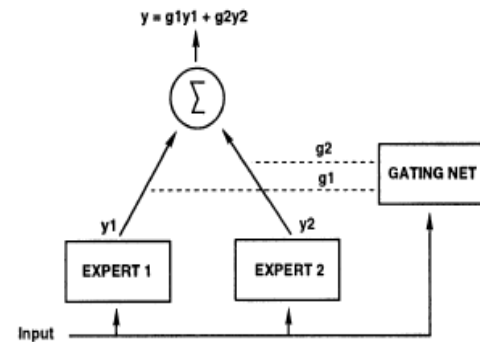

Multiple experts

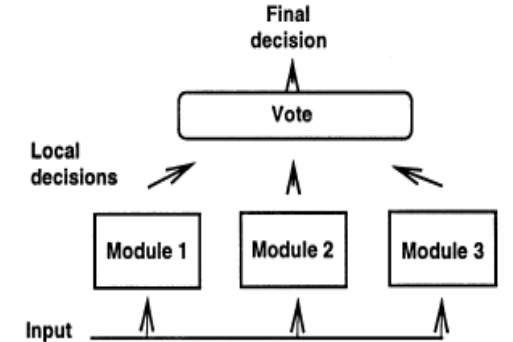

Ensemble (majority vote)

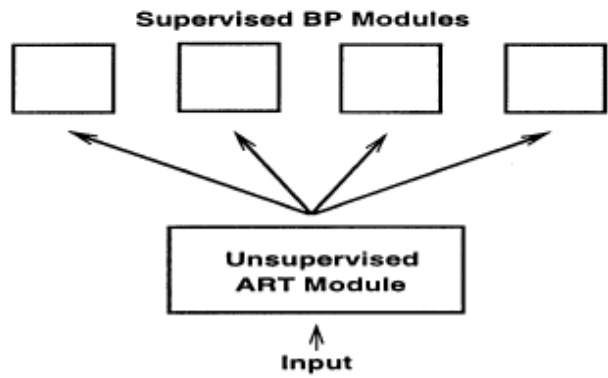

ART-BP model

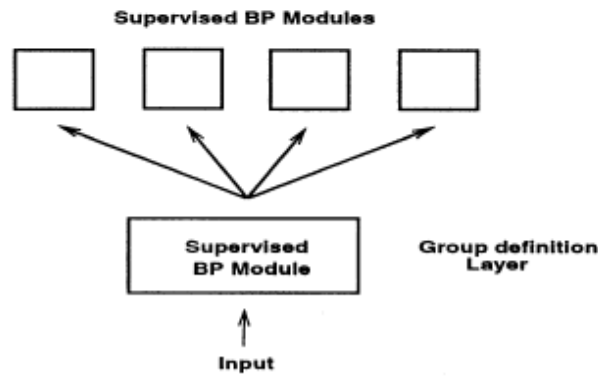

Hierarchical modules

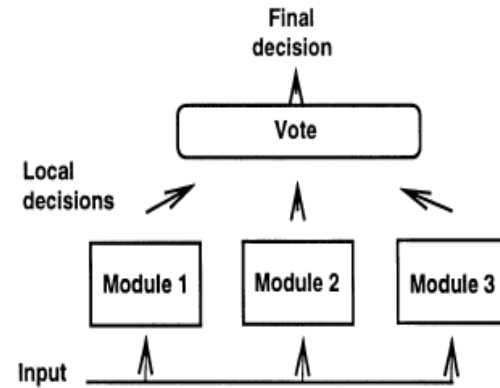

Ensemble (average vote)

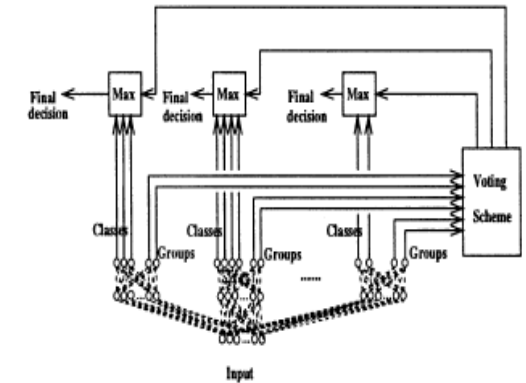

Cooperative MNN

Eight of the most common MNN architectures.

Section - II

Paper : **A modular neural network architecture with concept** By Yi Ding, Qi Feng, Tianjiang Wang, Xian Fu b

- Aim: Develop a parallel and fault tolerant MNN.
- Motivation: Human Nervous system.

Evolution of the Model

- Is the network **homogenous** or **heterogeneous**!
Are all modules of **one type** or are there **different types of modules** used!
- What type of architecture is used for the modules! MLP, LNN, SOM, ART
- How are the modules **interconnected**! Are only feedforward connections used are recurrent connections allowed are connections only made from one layer to next!
- What is the **general network structure**! Has the network a single layer or n layers

Evolution of the Model

- How are the **inputs connected** to the network! Are the inputs connected to all modules overlapping or only to one module non-overlapping!
- What training algorithm is used for the modules! Is a supervised or unsupervised learning method used!
- How is learning organized for the whole network! Does the network learn in stages? Is noise used during the training!

Evolution of the Model

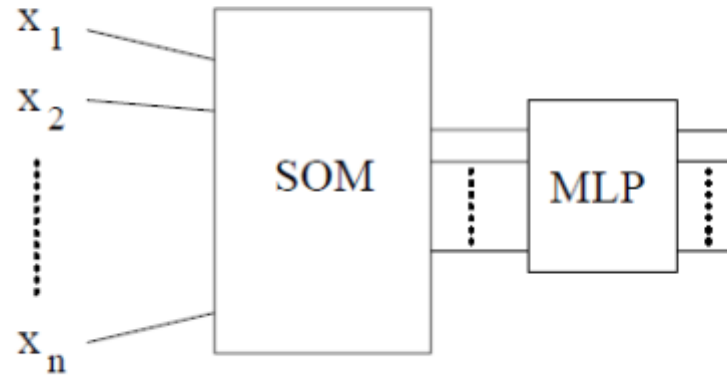

- A heterogeneous architecture consisting of two modules. One is a self-organizing map SOM and is used to reduce the input dimension the other one is a multilayer Perceptron that works on the reduced input space

Evolution of the Model

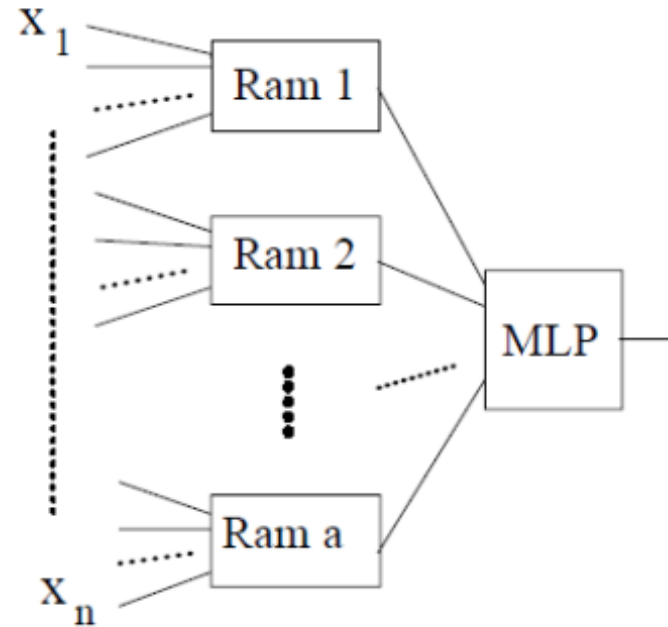

- MLP on the output of logical adaptive nodes is one idea for another heterogeneous structure

Evolution of the Model

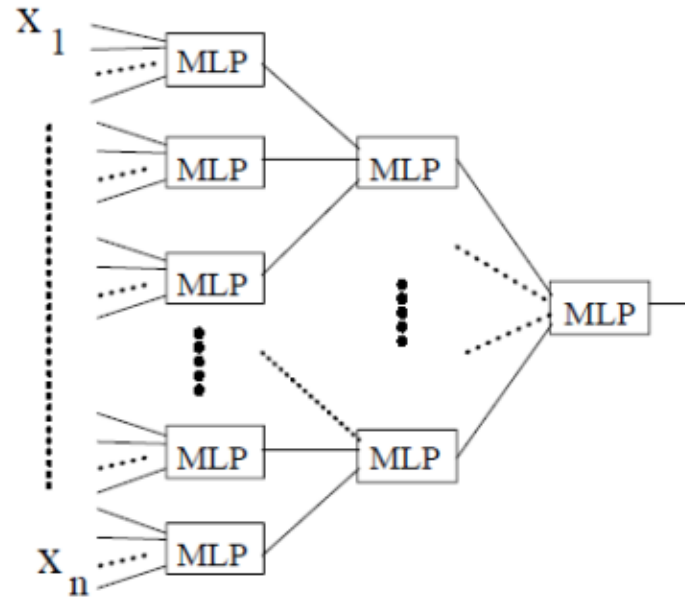

- A homogeneous pyramidal structure
- uses small MLPs instead of logical nodes
- This should provide fast training of the network as well as improved generalization ability

Evolution of the Model

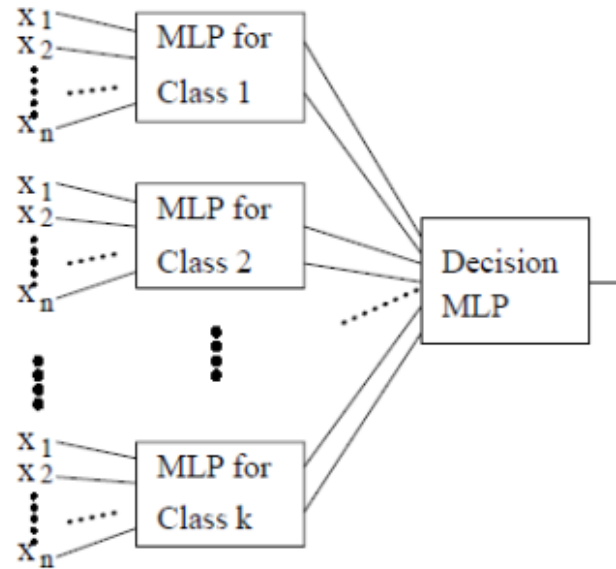

- The input and output dimensions of the problem remain the same
- Each subnetwork is only concerned with a single class

The Final Architecture:

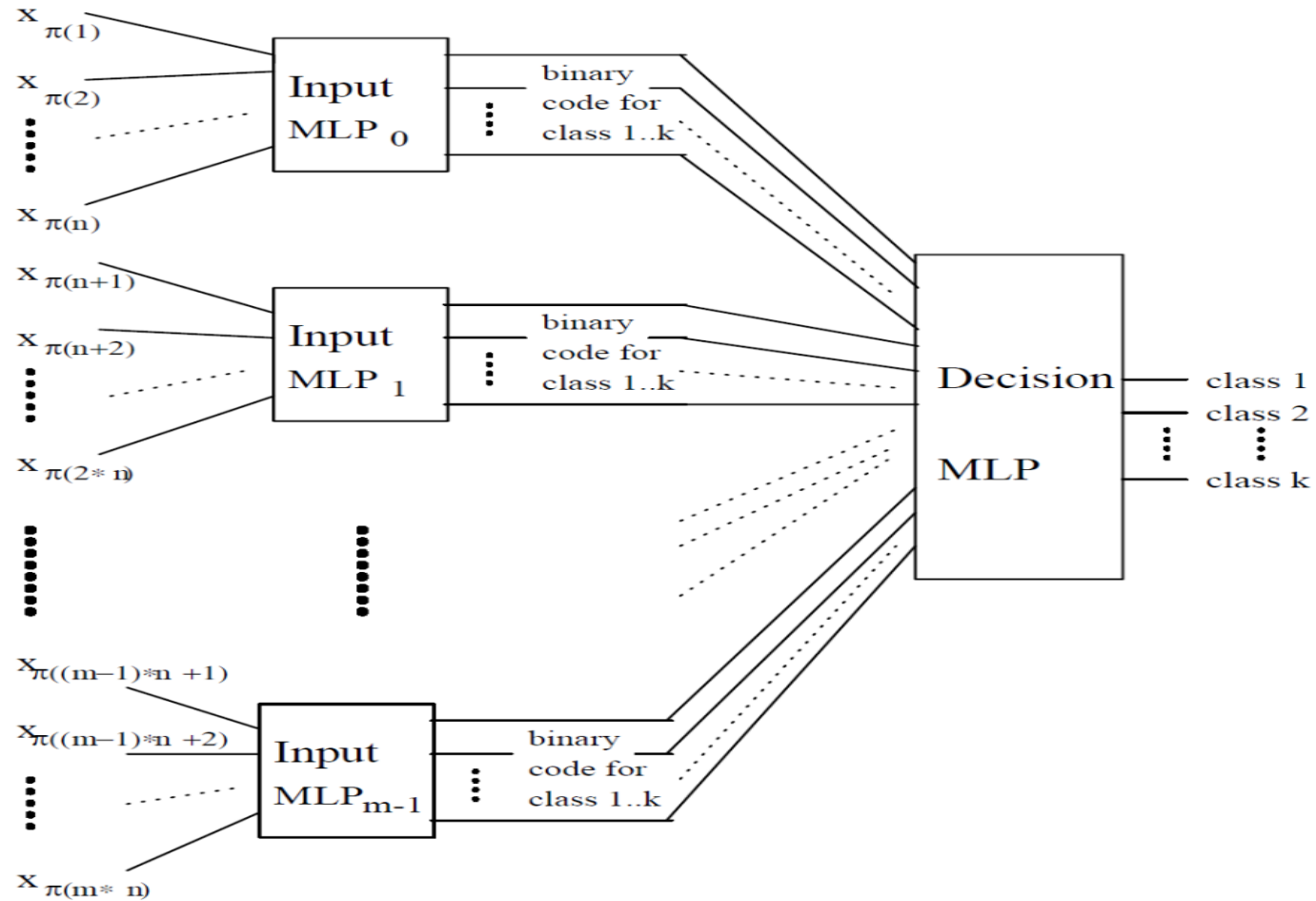

Figure 5.2: The Proposed Modular Neural Network Architecture.

Characteristics

- All sub-networks are MLPs
- the number of inputs and the number of outputs of the module is determined by the system
- The internal structure such as the number of hidden layers and the number of neurons in each hidden layer can be chosen independent of the overall architecture

Characteristics

- Each input variable is connected to only one of the input modules
- The function $\pi : X \rightarrow X$ gives a permutation on $X = \{1..l\}$
- This permutation is randomly chosen and constant for a network

Definition: A Module

A module is a multilayer feedforward neural network defined by a 3-tuple:

$$\mathcal{M} = (a, b, \mathcal{H})$$

Where a is the number of inputs of the module, b is the number of output nodes, and \mathcal{H} is a list containing the numbers of neurons in each of the hidden layers.

Example:

A multilayer Perceptron module \mathcal{M} with eight inputs, twelve neurons in the first hidden layers, ten neurons in the second hidden layer, and four outputs is described as: $\mathcal{M} = (8, 4, [12, 10])$.

Definition: A Modular Neural Network

A modular neural network is a set of interconnected modules defined by a 7-tuple.

$$N = (l, k, m, r, \pi, \mathcal{I}, \mathcal{D})$$

Where l is the number of inputs, k the number of classes, m the number of modules in the input layer, r is the type of the intermediate representation ($r \in \{small, large\}$), π is the permutation function, \mathcal{I} is the input layer module, and \mathcal{D} is the decision module.

Algorithm for MNN

The Training Algorithm:

- Stage 1 – Training the Input Layer:
 1. Select the training sets TS_i from the original training set TS , for all $i = 0 \dots m - 1$.
 2. Train all modules MLP_i on TS_i using the BP algorithm.
- Stage 2 – Training the Decision Network
 1. Calculate the response r of the first layer for each input vector j .
$$r^j = \Phi((x_1^j, x_2^j, \dots, x_l^j)).$$
 2. Build the training set for the decision network
$$TS_d = \{(r^j; d_{BIT}^j) | j = 1, \dots, t\}$$
 3. Train the decision network on the set TS_d using the BP algorithm

Generalization

- The proposed architecture combines two methods of generalization:
- One method is built in to the MLP. Each of the networks has the ability to generalize on its input space. This type of generalization is common to connectionist systems.
- The second method of generalization is due to the architecture of the proposed network. It is a way of generalizing according to the similarity of input patterns.

Training



Simplified 'H'

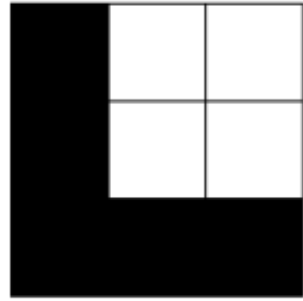

Simplified 'L'

(a)

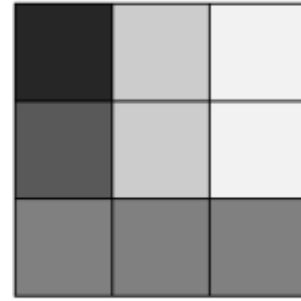

Distorted 'L'
Pattern 1

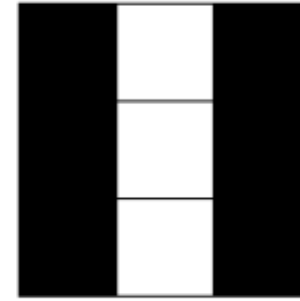

Distorted 'H'
Pattern 2

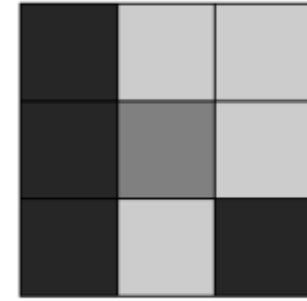

Distorted 'L'
Pattern 3

(b)

Figure 5.5: (a) The Training Set.

(b) The Test Set.

Example Architecture

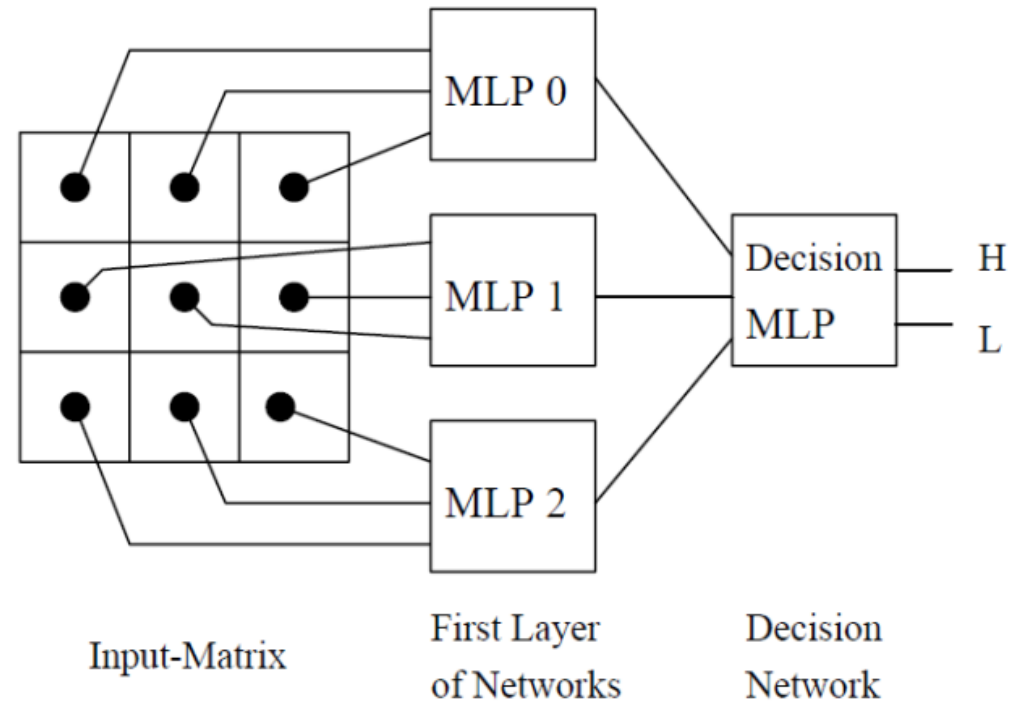

Training

- Input : 9 values between 0 and 1 (black = 1, white = 0)
- The network needs to be trained to recognize the simplified letters 'H' and 'L'
- Output: 'H' = 0 ; 'L' = 1

Training Subsets



Simplified 'H'

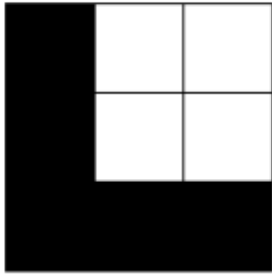

Simplified 'L'

MLP_0	MLP_1	MLP_2
$(1,0,1;0)$	$(1,1,1;0)$	$(1,0,1;0)$
$(1,0,0;1)$	$(1,0,0;1)$	$(1,1,1;1)$

Training Set for decision Network

$$(\Phi(1, 0, 1, 1, 1, 1, 1, 0, 1); 1, 0) = (0, 0, 0; 1, 0)$$

$$(\Phi(1, 0, 0, 1, 0, 0, 1, 1, 1); 0, 1) = (1, 1, 1; 0, 1)$$

Use Test Set

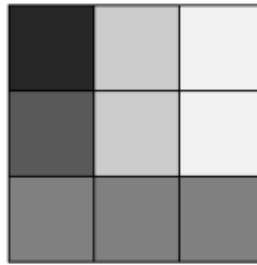

Distorted 'L'
Pattern 1

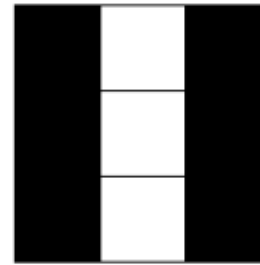

Distorted 'H'
Pattern 2

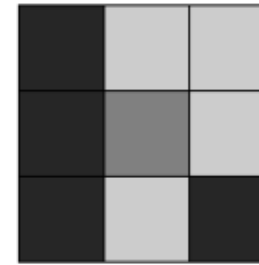

Distorted 'L'
Pattern 3

- The 1st character tests generalization within the input modules
- Second tests the generalization on the number of correct sub-patterns
- Third character is a combination of both

Global Decision Making (Classification)

$$\begin{aligned} r_1 &= \Psi(\Phi(0.9, 0.2, 0.1, 0.7, 0.2, 0.1, 0.5, 0.5, 0.5)) \\ &= \Psi(0.95, 0.86, 0.70) = (0.04, 0.96) \Rightarrow 'L' \end{aligned}$$

$$\begin{aligned} r_2 &= \Psi(\Phi(1.0, 0.0, 1.0, 1.0, 0.0, 1.0, 1.0, 0.0, 1.0)) \\ &= \Psi(0, 0.49, 0) = (0.91, 0.09) \Rightarrow 'H' \end{aligned}$$

$$\begin{aligned} r_3 &= \Psi(\Phi(0.9, 0.2, 0.2, 0.9, 0.5, 0.2, 0.9, 0.2, 0.9)) \\ &= \Psi(0.92, 0.65, 0.09) = (0.15, 0.89) \Rightarrow 'L' \end{aligned}$$

Benefits of Modular Neural Network

- **Efficiency**

The possible connections increases at a daunting rate as nodes are added to the network. Since computation time depends on the number of nodes and their connections, any increase here will have drastic consequences in the processing time. speedup of 10 times achieved.

- **Training**

A large neural network attempting to model multiple parameters can suffer from interference as new data can dramatically alter existing connections or just serve to confuse. With some foresight into the subtasks to be solved, each neural network can be tailored for its task. Unique training algorithm and training data for each sub-network . implemented much more quickly.

- **Robustness**

Regardless of whether a large neural network is biological or artificial, it remains largely susceptible to interference at and failure in any one of its nodes. By compartmentalizing subtasks, failure and interference are much more readily diagnosed and their effects on other sub-networks are eliminated as each one is independent of the other.

Benefits of Modular Neural Network

Reference :

A modular neural network architecture with concept, by Yi Dinga, Qi Fenga, Tianjiang Wanga, Xian Fub



Recognition
on Testset

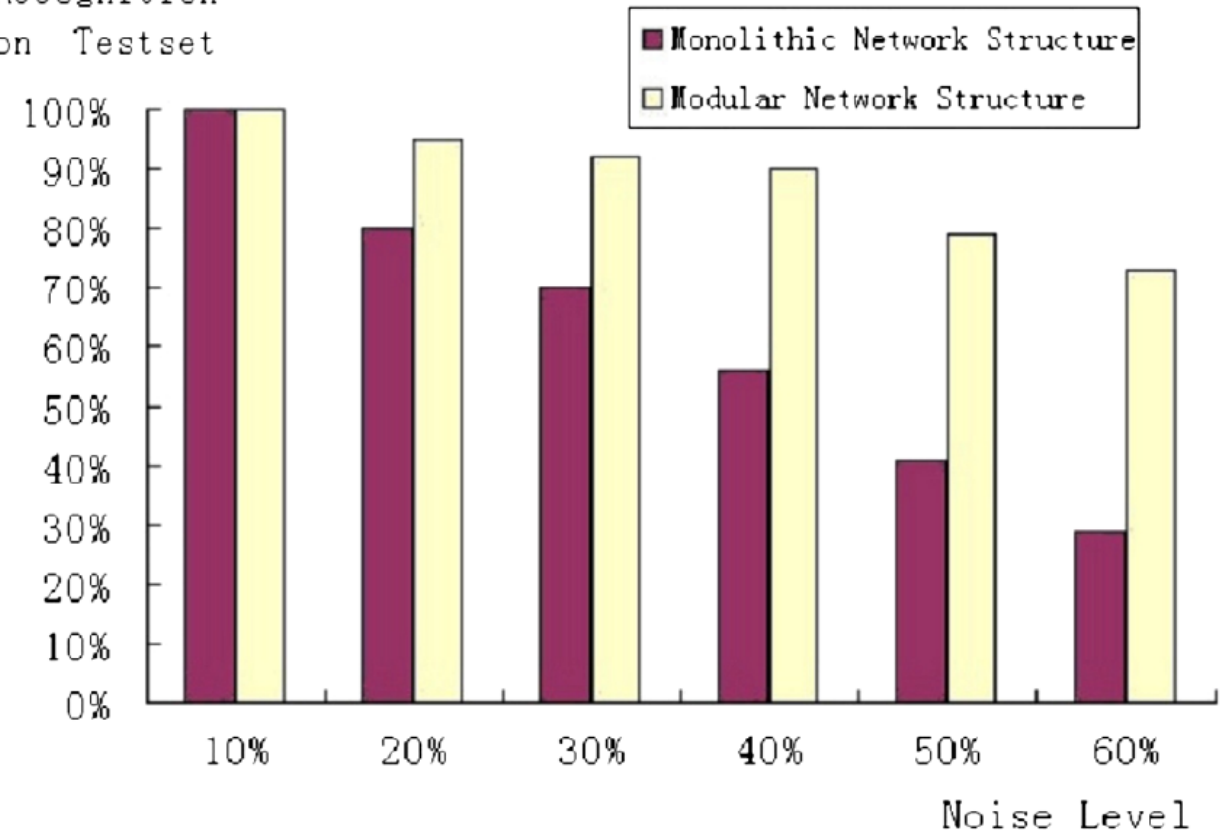

Fig. 3. The performance on noisy inputs.

Summary

- Modular Neural Networks, its connection to NN
- Motivations
- Benefits of MNN
- MNN Architecture
- Example of developing a MNN